**KLT-USB-0533 V1****2MP 0533 OmniVision OV2710 M12 Fixed Focus USB 2.0 Camera Module**

KLT-USB-0533 V1 is a 2MP Fixed Focus USB camera module based on 1/2.7" OV2710 image sensor. It delivers high-speed, 2K resolution ultra sharp image.

The S-mount (M12) lens holder enables customers to choose different lens as per varies applications. This camera module is ideal solution for face recognition, identity detection, access control.

Key Features

- 2K resolution (1920 x 1080) OmniVision OV2710 sensor
- High speed USB 2.0 Plug and Play
- MJPG and YUV2 output format
- Low power consumption
- Compact size
- UVC compliant to Windows, Linux, OS with UVC driver
- USB OTG (On-The-Go) support

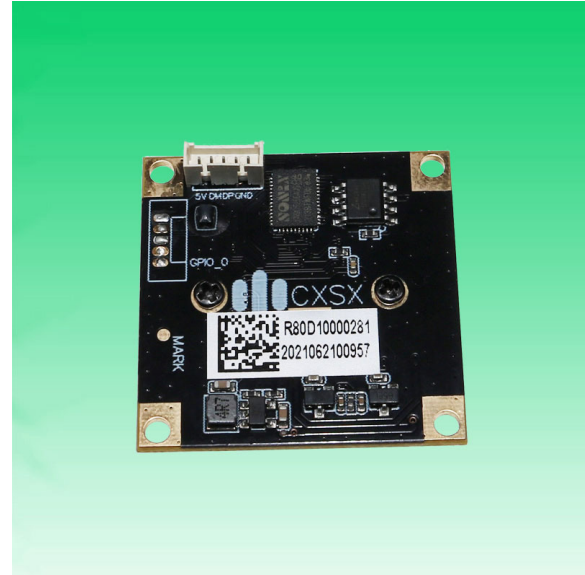

KLT-USB-0533 V1

2MP 0533 OmniVision OV2710 M12 Fixed Focus USB 2.0 Camera Module

Camera Module No.	KLT-USB-0533 V1
Resolution	2MP
Image Sensor	OV2710
Sensor Type	1/2.7"
Pixel Size	3.0 um x 3.0 um
EFL	3.00 mm
F.NO	2.80
Pixel	1920 x 1080
View Angle	96.0°(DFOV) 81.8°(HFOV) 65.8°(VFOV)
Lens Dimensions	13.20 x 13.20 x 22.50 mm
Module Type	Fixed Focus
Lens Model	KLT-LENS-0533 V1
Interface	USB 2.0
Output Format	MJPEG / YUV2
Auto Control	Saturation, Contrast, Acutance White Balance, Exposure
Audio	None
Input Voltage	DC 5V
Working Current	Max 500mA
PCB Size	32 x 32 mm
System Compatibility	Windows XP (SP2, SP3), Vista, 7, 8, 10, 11 Android, Mac OS, Linux or OS with UVC Driver Raspberry Pi by USB Port
Software for USB Camera	AMCAP, Webcam Viewer, V4L2 Controls Contacam, VLC Player, MotionEye OS iSpy, ZoneMider, Yawcam
Lens Type	650nm IR Cut
Operating Temperature	-30°C to +85°C
USB Cable	KLT-Cable-U013

Wide Compatibility with Windows, Android, Mac OS, Linux, or Raspberry Pi



www.KaiLapTech.com sales@KaiLapTech.com Tel: (852) 6908 1256 Fax: (852) 3017 6778



KLT-USB-0533 V1

2MP 0533 OmniVision OV2710 M12 Fixed Focus USB 2.0 Camera Module



Top View



Side View



Bottom View



Mating Connector

**KLT-USB-0533 V1****2MP 0533 OmniVision OV2710 M12 Fixed Focus USB 2.0 Camera Module**

FORMAT	RESOLUTION	FRAME RATE
		USB 2.0
MJPG	640 x 480 (VGA)	30 FPS
	1280 x 720 (720P)	30 FPS
	1920 x 1080 (1080P)	30 FPS
	640 x 480 (VGA)	30 FPS
YUV2	1280 x 720 (720P)	10 FPS
	1920 x 1080 (1080P)	5 FPS
	1920 x 1080 (1080P)	5 FPS
	2592 x 1944 (5MP)	2 FPS







your BEST camera module partner

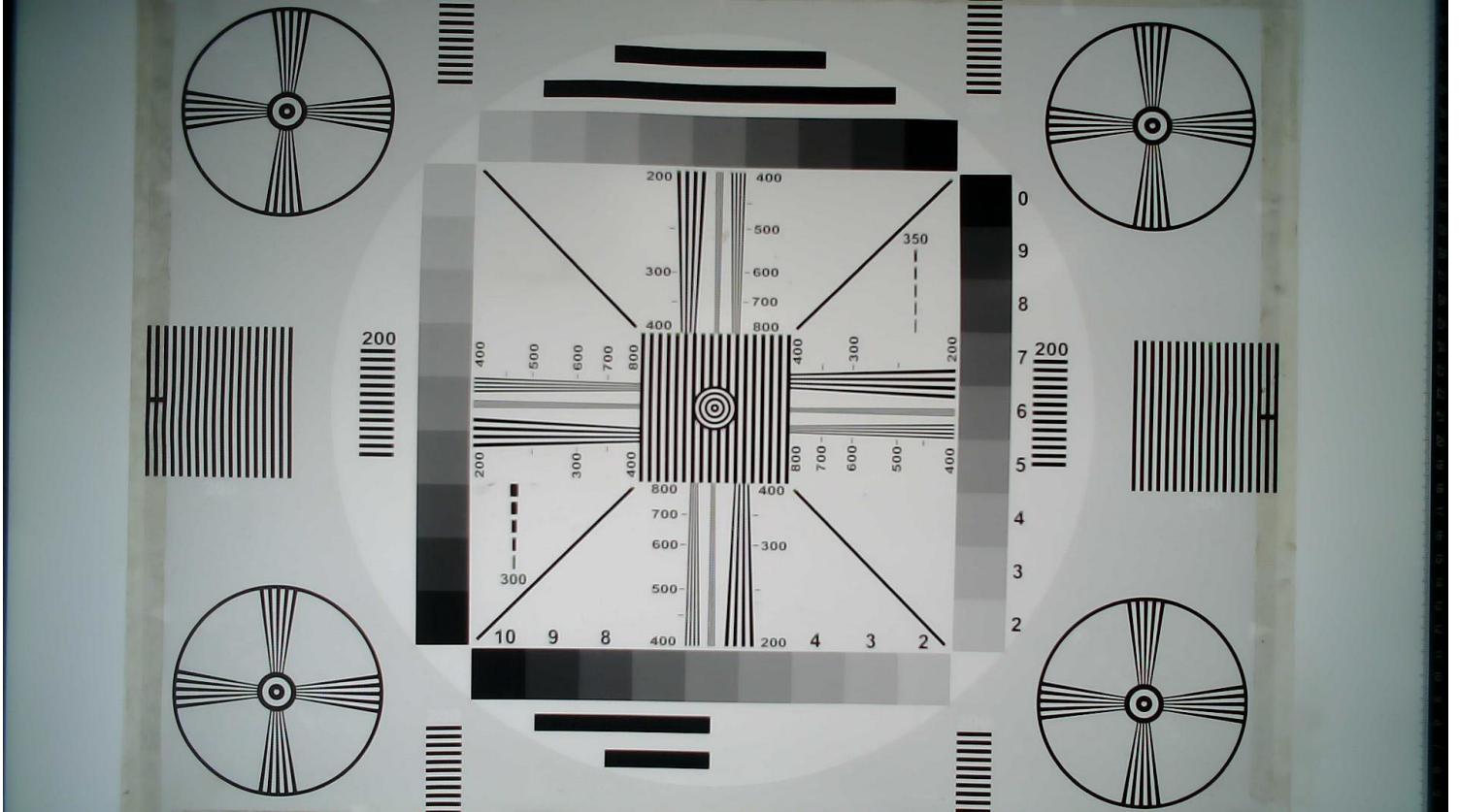



your BEST camera module partner



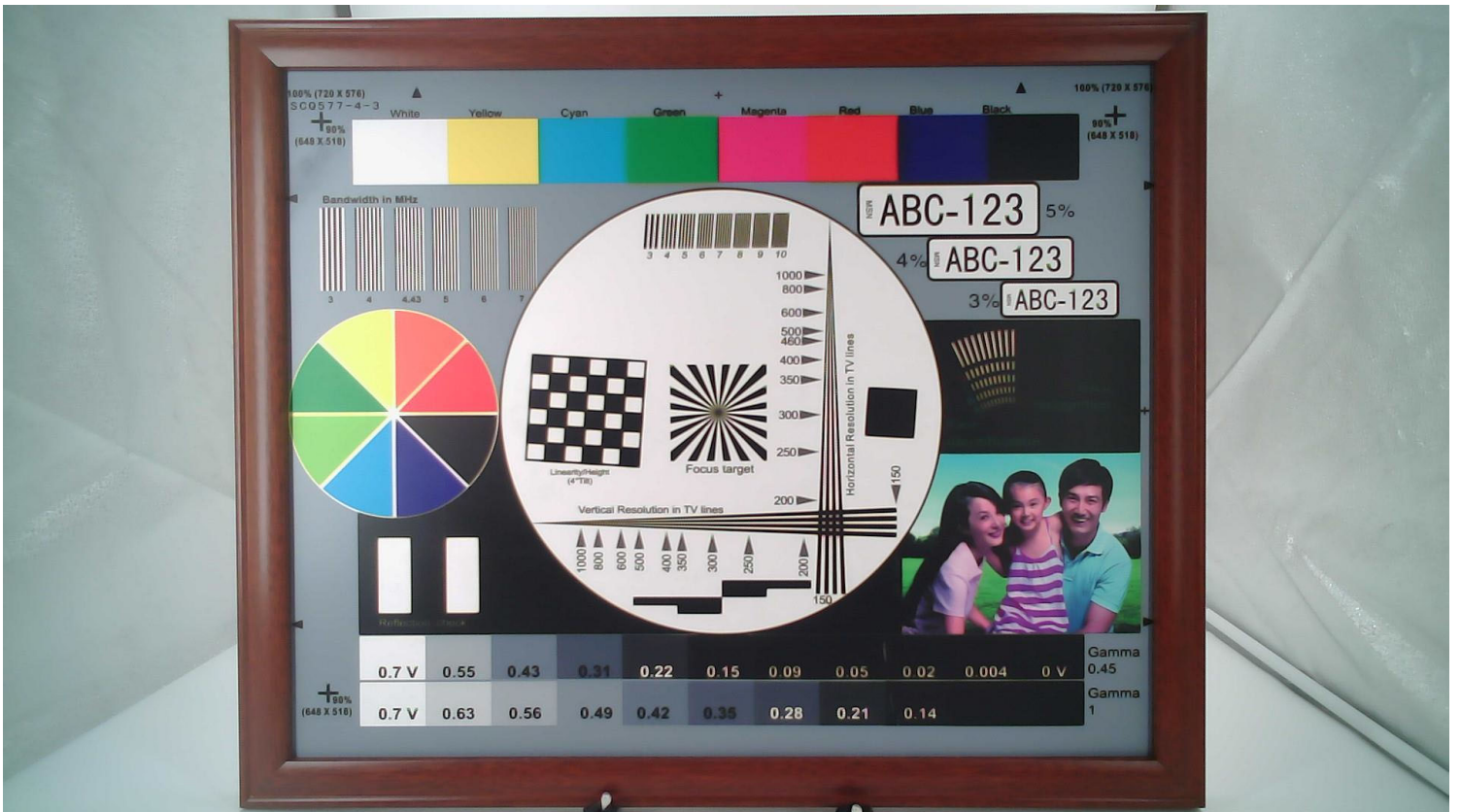
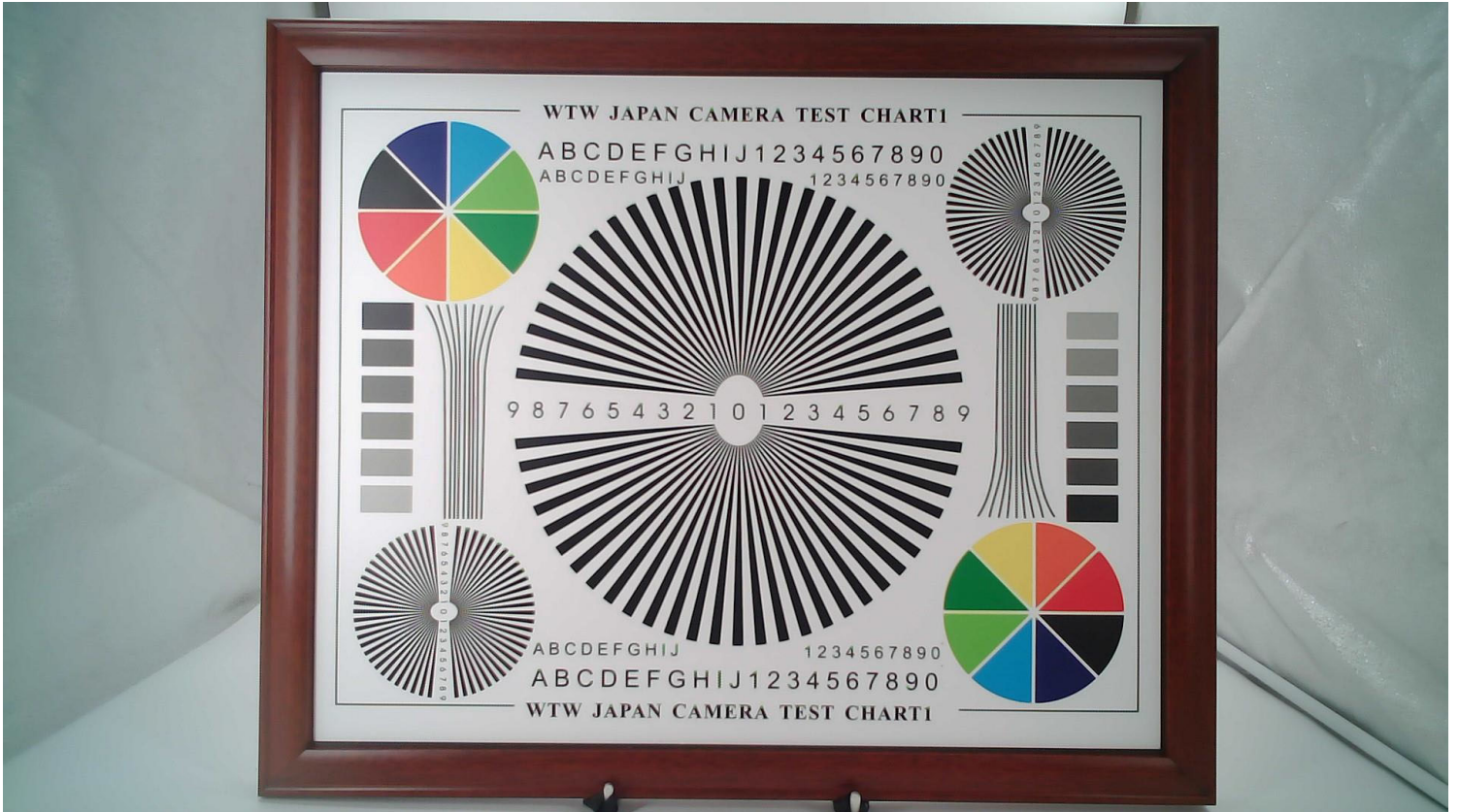

Version	Information	Date
V1.0	First Version	8-16-2022

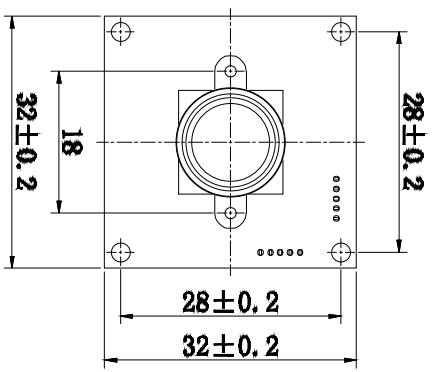
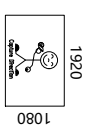

TOP VIEW

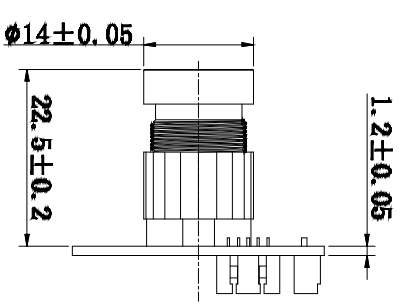

SIDE VIEW

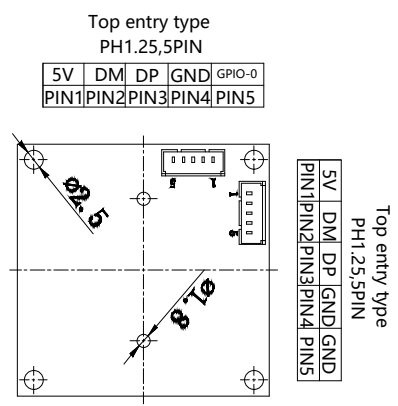

BOTTOM VIEW

Parameters:

1、Sensor specification:

Image Sensor: OV2710
 Pixel: 3.0um×3.0um
 Lens Type: 1/2.7
 Important Voltage Description: USB 5V
 (external power supply);

2、Lens specification:

FOV: 96°(D);81.8°(H);65.8°(V)
 F/NO.: 2.8
 TV distortion: <-0.7%
 Focal length: 3.0mm
 Composition: 2P2G+IR FILTER
 IR Cut Coating: 650nm±10nm@50%

Kai Lap Technologies Group Ltd

Designed By

Kevin

Model Name:

KLT-USB-0533 V1

Checked By

Jacky

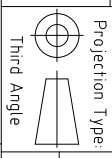

Unit: mm
 Scale: 1:1

Material: -----
 Sheet: 1 of 1

Version: 1/0

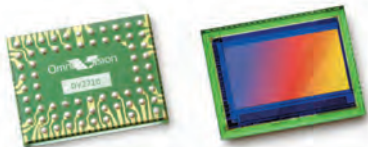

OV2710-1E full HD (1080p) product brief



OmniVision's True 1080p High Definition (HD) Video Image Sensor



available in
a lead-free
package

The OV2710-1E is a true full HD (1080p) CMOS image sensor designed specifically to deliver high-end HD video to digital video camcorders, notebooks, PC webcam, security and other mobile applications. The 1/2.7-inch OV2710-1E addresses the fast growing demand for affordable, HD-quality digital video solutions for video conferencing and recording.

The OV2710-1E is among the very first no-compromise full HD (1080p) sensors available on the market, meaning it offers HD video format with a display resolution of 1920 x 1080 pixels, operating at 30 frames per second. Built with OmniVision's proprietary 3 μ m OmniPixel3-HS™ high sensitivity pixel technology, the OV2710-1E delivers low-light sensitivity of 3700 mV/lux-sec, S/N ratio of 40 dB, and

a peak dynamic range of 69 dB, enabling cameras to operate in virtually every lighting condition from bright daylight to nearly complete darkness below 15 lux.

The OV2710-1E supports multiple platform architectures and controllers with both parallel and MIPI interfaces. By allowing system designers to leverage the same opto-electrical design across various products and multiple market segments, the OV2710-1E significantly reduces product development time. OmniVision's OmniPixel3-HS pixel technology has already been proven in high quality webcam/video applications and is now available in 1080p full HD in the OV2710-1E.

Find out more at www.ovt.com.



OmniVision

Applications

- Notebooks
- PC Webcams
- Camcorders
- Security
- Digital Still Cameras
- Telepresence
- Portable Media Players

Product Features

- programmable controls: gain, exposure, frame rate, image size, horizontal mirror, vertical flip, cropping, windowing, and panning
- automatic image control functions:
 - automatic exposure (AEC)
 - automatic gain control (AGC)
 - automatic white balance (AWB)
 - automatic black level calibration (ABLCL)
- serial camera control bus (SCCB)
- lens correction (LENC)
- defect pixel correction (DPC)
- support for digital video port (DVP) parallel output interface
- integrated auto focus filter
- support for one lane MIPI interface (up to 800 Mbps)
- support for 8-/10-bit RAW RGB output format
- support for image sizes:
 - 1080p at 30 fps
 - cropped 720p at 60 fps
 - VGA at 120 fps
- support for black sun cancellation
- embedded one-time programmable (OTP) memory
- on-chip phase lock loop (PLL)
- built-in 1.5V regulator for core

OV2710-1E



Ordering Information

- OV2710-A68A-1E
(color, lead-free, 68-pin CSP3)

Product Specifications

- active array size: 1920 x 1080
- power supply:
 - analog: 3.0 - 3.6V (3.3V typical)
 - core: 1.425 - 1.575V (1.5V typical)
 - I/O: 1.7 - 3.6V (1.8V typical)
- power requirements:
 - active: 350 mW
 - power down: 70 μ A
- temperature range:
 - operating: -30°C to +85°C junction temperature
 - stable image: 0°C to +65°C junction temperature
- output interfaces: 10-bit parallel/one lane MIPI
- output formats: 10-bit RAW RGB
- lens size: 1/2.7"
- lens chief ray angle: 23.6°
- input clock frequency: 6 - 27 MHz
- scan mode: progressive
- maximum image transfer rate:
 - 1080p: 30 fps
 - cropped 720p: 60 fps
 - VGA: 120 fps
 - QVGA: 240 fps
- sensitivity: 3700 mV/lux-sec
- shutter: rolling
- max S/N ratio: 40 dB
- dynamic range: 69 dB @ 8x gain
- maximum exposure interval: 1096 tline
- pixel size: 3 μ m x 3 μ m
- dark current: 20 mV/sec @ 60°C junction temperature
- image area: 5856 μ m x 3276 μ m
- package dimensions: 7465 μ m x 5865 μ m

Functional Block Diagram

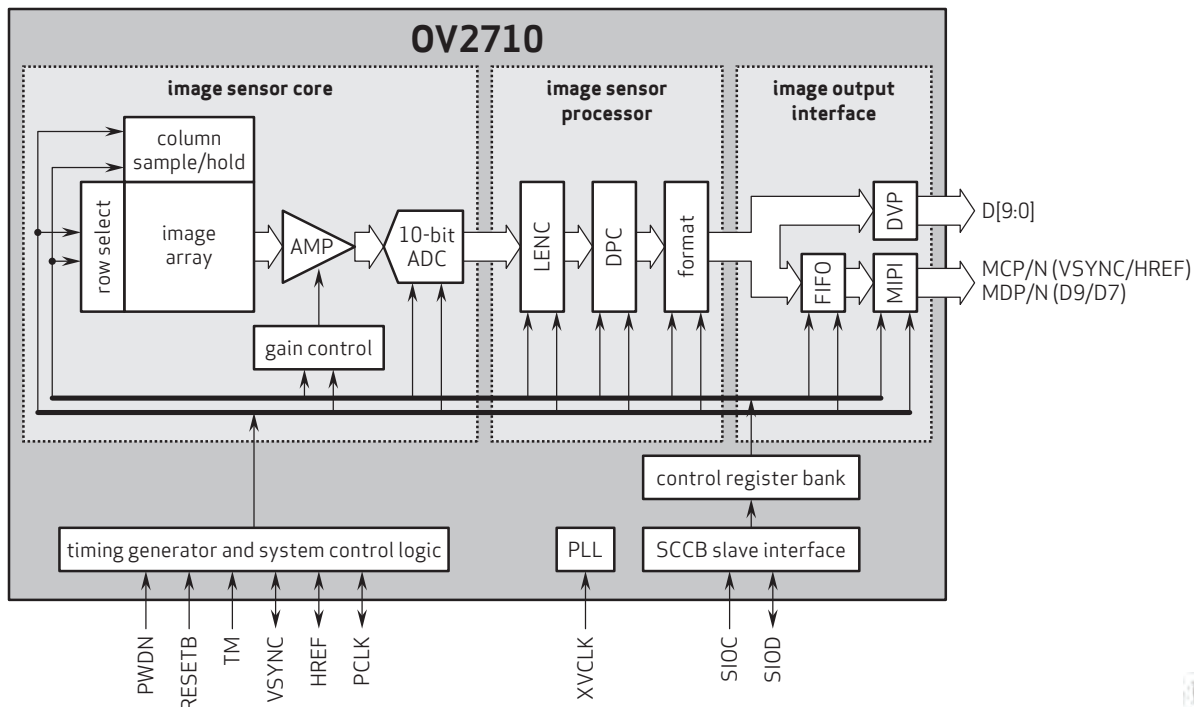

4275 Burton Drive
Santa Clara, CA 95054
USA

Tel: +1 408 567 3000
Fax: +1 408 567 3001
www.ovt.com

OmniVision reserves the right to make changes to their products or to discontinue any product or service without further notice. OmniVision, the OmniVision logo and OmniPixel are registered trademarks of OmniVision Technologies, Inc. OmniPixel3-H5 is a trademark of OmniVision Technologies, Inc. All other trademarks are the property of their respective owners.



OmniVision



your **BEST** camera module partner

Cameras Applications





Camera Reliability Test

Reliability Inspection Item		Testing Method	Acceptance Criteria	
Category	Item			
Environmental	Storage Temperature	High 60°C 96 Hours	Temperature Chamber	No Abnormal Situation
		Low -20°C 96 Hours	Temperature Chamber	No Abnormal Situation
	Operation Temperature	High 60°C 24 Hours	Temperature Chamber	No Abnormal Situation
		Low -20°C 24 Hours	Temperature Chamber	No Abnormal Situation
	Humidity	60°C 80% 24 Hours	Temperature Chamber	No Abnormal Situation
	Thermal Shock	High 60°C 0.5 Hours Low -20°C 0.5 Hours Cycling in 24 Hours	Temperature Chamber	No Abnormal Situation
Physical	Drop Test (Free Falling)	Without Package 60cm	10 Times on Wood Floor	Electrically Functional
		With Package 60cm	10 Times on Wood Floor	Electrically Functional
	Vibration Test	50Hz X-Axis 2mm 30min	Vibration Table	Electrically Functional
		50Hz Y-Axis 2mm 30min	Vibration Table	Electrically Functional
		50Hz Z-Axis 2mm 30min	Vibration Table	Electrically Functional
	Cable Tensile Strength Test	Loading Weight 4 kg 60 Seconds Cycling in 24 Hours	Tensile Testing Machine	Electrically Functional
Electrical	ESD Test	Contact Discharge 2 KV	ESD Testing Machine	Electrically Functional
		Air Discharge 4 KV	ESD Testing Machine	Electrically Functional
	Aging Test	On/Off 30 Seconds Cycling in 24 Hours	Power Switch	Electrically Functional
	USB Connector	On/Off 250 Times	Plug and Unplug	Electrically Functional





Inspection Item		Inspection Method	Standard of Inspection		
Category	Item				
Appearance	FPC/ PCB	Color	The Naked Eye	Major Difference is Not Allowed.	
		Be Torn/Chopped	The Naked Eye	Copper Crack Exposure is Not Allowed.	
		Marking	The Naked Eye	Clear, Recognizable (Within 30cm Distance)	
	Holder	Scratches	The Naked Eye	The Inside Crack Exposure is Not Allowed	
		Gap	The Naked Eye	Meet the Height Standard	
		Screw	The Naked Eye	Make Sure Screws Are Presented (If Any)	
		Damage	The Naked Eye	The Inside Crack Exposure is Not Allowed	
	Lens	Scratch	The Naked Eye	No Effect On Resolution Standard	
		Contamination	The Naked Eye	No Effect On Resolution Standard	
		Oil Film	The Naked Eye	No Effect On Resolution Standard	
		Cover Tape	The Naked Eye	No Issue On Appearance.	
	Function	Image	No Communication	Test Board	Not Allowed
			Bright Pixel	Black Board	Not Allowed In the Image Center
Dark Pixel			White board	Not Allowed In the Image Center	
Blurry			The Naked Eye	Not Allowed	
No Image			The Naked Eye	Not Allowed	
Vertical Line			The Naked Eye	Not Allowed	
Horizontal Line			The Naked Eye	Not Allowed	
Light Leakage			The Naked Eye	Not Allowed	
Blinking Image			The Naked Eye	Not Allowed	
Bruise			Inspection Jig	Not Allowed	
Resolution			Chart	Follows Outgoing Inspection Chart Standard	
Color			The Naked Eye	No Issue	
Noise			The Naked Eye	Not Allowed	
Corner Dark			The Naked Eye	Less Than 100px By 100px	
Color Resolution			The Naked Eye	No Issue	
Dimension	Height	The Naked Eye	Follows Approval Data Sheet		
	Width	The Naked Eye	Follows Approval Data Sheet		
	Length	The Naked Eye	Follows Approval Data Sheet		
	Overall	The Naked Eye	Follows Approval Data Sheet		



KLT Package Solutions

KLT Camera Module

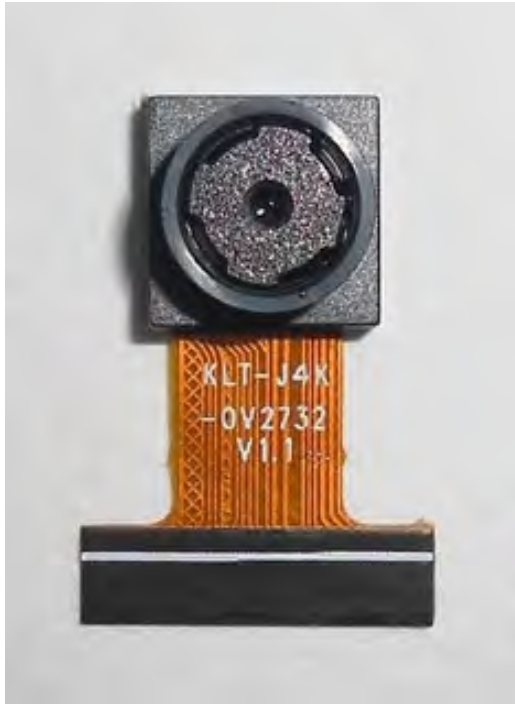

Complete with Lens Protection Film



Tray with Grid and Space



Place Cameras on the Tray

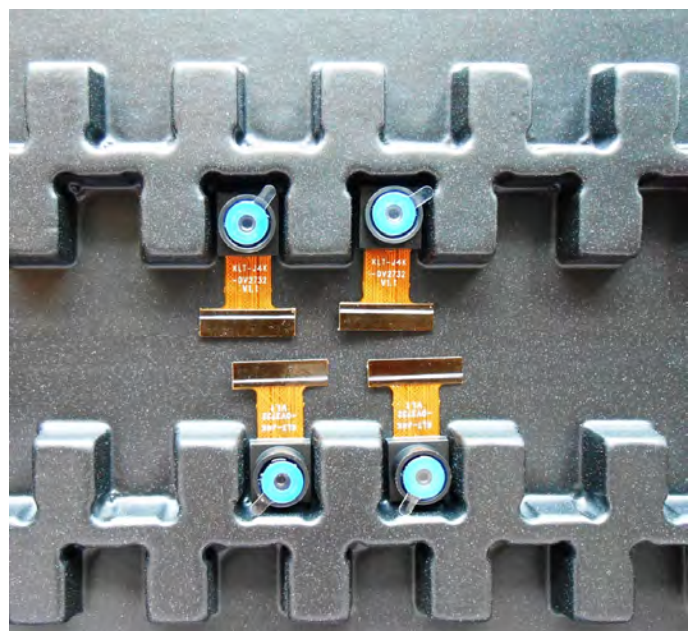



Camera Modules Package Solution

Full Tray of Cameras



Cover Tray with Lid



Put Tray into Anti-Static Bag



Vacuum the Anti-Static Bag

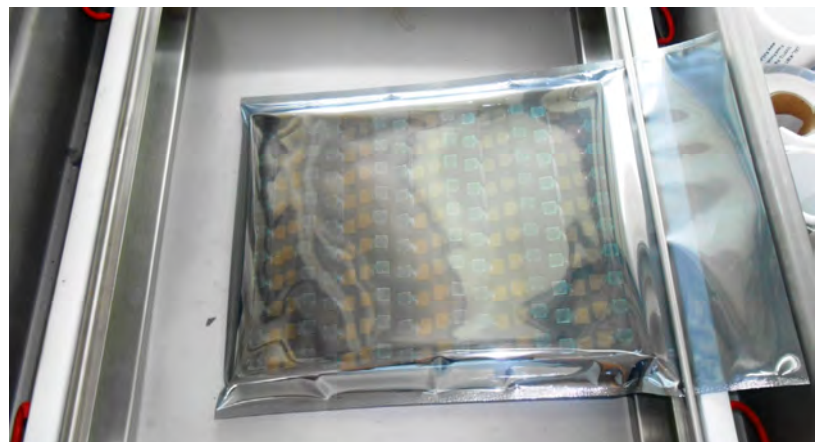



Camera Modules Package Solution

Sealed Vacuum Bag with Labels

1. Model and Description 2. Quantity 3. Shipping Date 4. Caution





Large Order Package Solution

Place Foam Sheets Between Trays



Foam Sheets are Slightly Larger than Trays



Place Foam Sheets and Trays into Box



Foam Sheets are Tightly Fitting Box





Small Order Package Solution

Place Foam Sheets and Trays into Small Box



Foam Sheets are Nicely Fitting the Small Box



Package in Small Box for Shipment



Place Small Boxes into Larger Box





Carbon Box Package Solution

Seal the Carbon Box

Final Package Labelled Box



Carbon Box Ready for Shipment

1. Delivery Address and Phone No. 2. Box No. and Ship Date 3. Fragile Caution





Sample Order Package Solution

Place Sample into Small Anti-Static Bag



Place Connectors into Small Ant-Static Bag



Sample Labels on the Small Bag

1. Camera Module or Connector Model
2. Shipping Date and Quantity
3. Caution





Connectors Large Order Package Solution

Connectors in a Wheel



Label Connectors in the Wheel



The Wheel is Perfectly Fitting the Box



Connectors Box Ready for Shipment





Company Kai Lap Technologies (KLT)

Kai Lap Technologies Group Limited. (KLT) was established in 2009, a next-generation technology driven manufacturer specialized in research, design, and produce of audio and video products. KLT is occupying 20,000 square feet automated plants with 100 employees of annual throughput 30,000,000 units cameras.

KLT provides OEM, ODM design, contract manufacturing, and builds the camera products. You may provide the requirements to us, even with a hand draft, our sales and engineering work together to meet your needs. We consider ourselves your last-term partner in developing practical and innovative solutions.

Our team covers everything from initial concept development to mass produced product. KLT specializes in customized camera design, raw material, electronic engineering, firmware/software development, product testing, and packing design. Our experienced strategic supply systems offer a robust and dependable manufacturing capacity for orders of various sizes.

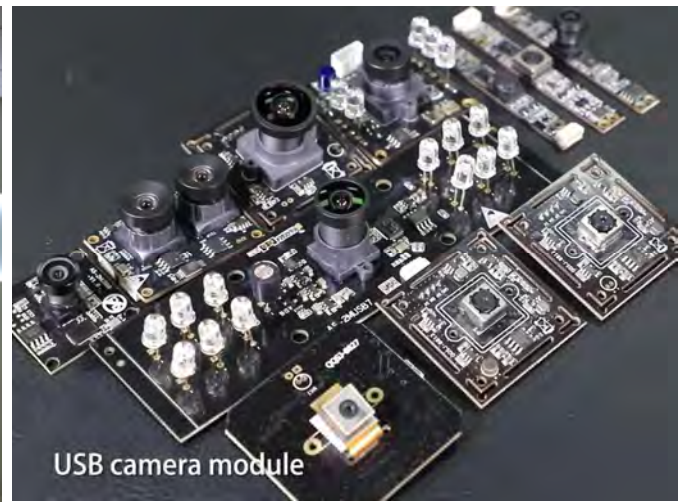

Limited Warranty

KLT provides the following limited warranty if you purchased the Product(s) directly from KLT company or from KLT's website, www.KaiLapTech.com. Product(s) purchased from other sellers or sources are not covered by this Limited Warranty. KLT guarantees that the Product(s) will be free from defects in materials and workmanship under normal use for a period of one (1) year from the date you receive the product ("Warranty Period").

For all Product(s) that contain or develop material defects in materials or workmanship during the Warranty Period, KLT will, at its sole option, either: (i) repair the Product(s); (ii) replace the Product(s) with a new or refurbished Product(s) (replacement Product(s) being of identical model or functional equivalent); or (iii) provide you a refund of the price you paid for the Product(s).

This Limited Warranty of KLT is solely limited to repair and/or replacement on the terms set forth above. KLT is not reliable or responsible for any subsequent events.





CMOS CAMERA MODULES



your BEST camera module partner

KLT Strength

Powerful Factory



Professional Service



Promised Delivery



www.KaiLapTech.com sales@KaiLapTech.com Tel: (852) 6908 1256 Fax: (852) 3017 6778

All rights reserved @ Kai Lap Technologies Group Ltd. Specifications subject to change without notice.